

N 982.2. Führungssäule, Gewinde beidseitig (zum Einpressen)

nach DIN 9825, ISO 9182-2

Produkteigenschaften

Material: Stahl, 18NiCrMo5, gehärtet 62-64 HRC
Ausführung: Führungsdurchmesser feingeschliffen und subfiniert
Aufnahmebohrung d1: in Grauguss -0,025 -0,035
in Stahl -0,015 -0,025

d1	10	12	15	16	19	20	24	25	30	32	38	40	48	50	63	80
	ohne Gewinde		mit Gewinde M8													

L1	10	12	15	16	19	20	24	25	30	32	38	40	48	50	63	80
90	●	●	●	●												
100	●	●	●	●	●	●	●	●								
112	●	●	●	●	●	●	●	●								
125	●	●	●	●	●	●	●	●	●	●						
140	●	●	●	●	●	●	●	●	●	●						
160			●	●	●	●	●	●	●	●	●	●				
180			●	●	●	●	●	●	●	●	●	●	●	●		
200			●	●	●	●	●	●	●	●	●	●	●	●	●	
224					●	●	●	●	●	●	●	●	●	●	●	●
250							●	●	●	●	●	●	●	●	●	●
280							●	●	●	●	●	●	●	●	●	●
315								●	●	●	●	●	●	●	●	●
355										●	●	●	●	●	●	●
400										●	●	●	●	●	●	●
450												●	●	●	●	●
500													●	●	●	●
550										●	●	●	●	●	●	●
600										●	●	●	●	●	●	●
700										●	●	●	●	●	●	●
800										●	●	●	●	●	●	●



Zeichnung zu N 982.2.

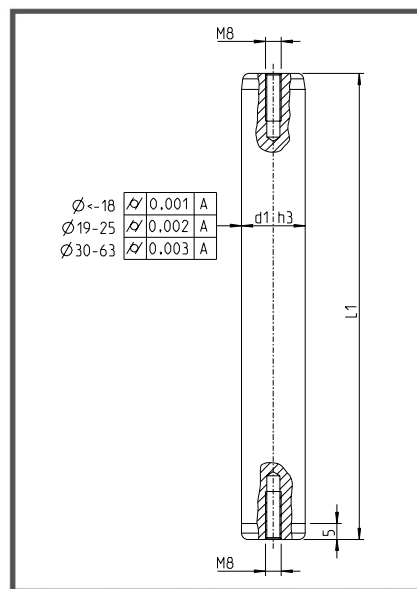

Führungssäule zum Einpressen, Gewinde beidseitig erhältlich ab \varnothing 15 mm, bis \varnothing 12 mm ohne Gewinde

Bestellbeispiel:

N982.2.20.200
 Führungssäule Durchmesser 20 mm, Länge 200 mm,
 Gewinde beidseitig

Einbaumöglichkeiten

