

N 9047. Führungsbuchse
bronzebeschichtet

i **Produkteigenschaften**

Material: Stahl, 18NiCrMo5, gehärtet 64 ± 2 HRC, Bronze: GSnPbBz10

Ausführung: feingeschliffen & gehont (DIN 9831/ISO 9448), Aufnahmebohrung ISO H5

N 9047. Führungsbuchse

d1	d2	L
15	28	23
		30
		37
		47
		60
23		
30		
37		
47		
60		
16	32	23
		30
		37
		47
		60
77		
23		
30		
37		
47		
60		
19	40	23
		30
		37
		47
		60
77		
23		
30		
37		
47		
60		
20	48	23
		30
		37
		47
		60
77		
23		
30		
37		
47		
60		
24	85	23
		30
		37
		47
		60
77		
23		
30		
37		
47		
60		
25	105	23
		30
		37
		47
		60
77		
23		
30		
37		
47		
60		
30	135	23
		30
		37
		47
		60
77		
95		

d1	d2	L	
32	48	30	
		37	
		47	
		60	
		77	
38	58	95	
		30	
		37	
		47	
		60	
77			
95			
40		70	120
			30
			37
	47		
	60		
77			
95			
48	85		120
			37
			47
		60	
		77	
95			
50		105	120
			37
			47
			60
	77		
95			
63	135		60
			77
			95
			120
		135	



Zeichnung zu N 9047.

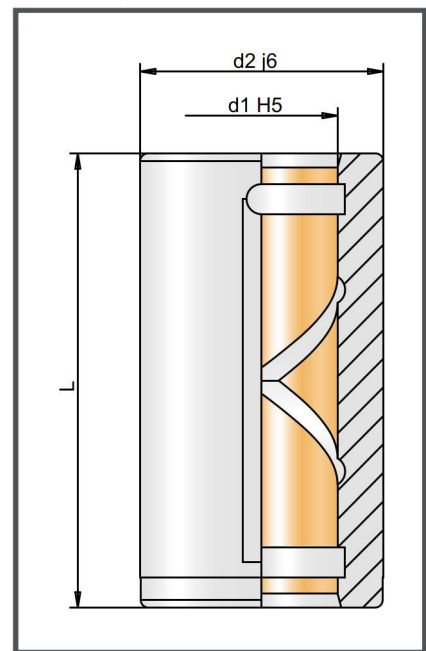

Bestellbeispiel:
N9047.15.23 Führungsbuchse,
Säulendurchmesser d1 = 15 mm,
Länge L = 23 mm