

5152. Führungslasche

Stahl mit Festschmierstoff, VDI 3387

i **Produkteigenschaften**

Material: Stahl, oberflächengehärtet
Gleitflächen mit eingelagertem Festschmierstoff (20 - 25 %)

Hinweis: Lieferung ohne Schrauben



Bestellbeispiel:
5152.063.180.25
Führungslasche
a = 63,0 mm
L1 = 180,0 mm
b = 25,0 mm

Bestellbeispiel:
5152.140.315.45
Führungslasche
a = 140,0 mm
L1 = 315,0 mm
b = 45,0 mm

Zeichnung zu 5152. (3 Schrauben)

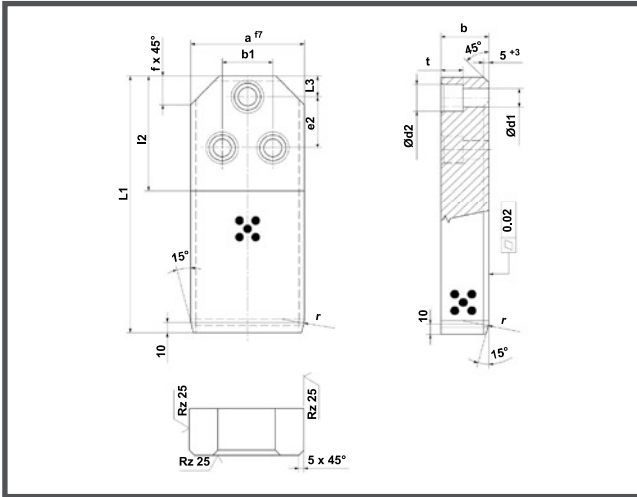

Zeichnung zu 5152. (4 Schrauben ab 140 x 315 mm)



Tabelle zu 5152. (3 Schrauben)

a	L1	b	e1	L3	e2 ±0,2	f	r	t	l2	Ø d1/d2
63	180	25	36	20	50	18	16	16	90	14/20
	200									
	224									
	180									
	200									
71	180	25	36	20	50	18	16	16	90	14/20
	200									
	224									
	180									
	200									
90	224	36	50	20	50	28	25	21	100	18/26
	200									
	224									
	250									
	200									
112	224	36	50	20	50	28	25	21	100	18/26
	200									
	224									
	250									
	200									

Tabelle zu 5152. (4 Schrauben ab 140 x 315 mm)

a	L1	b	e1	L3	e2 ±0,2	f	r	t	l2	Ø d1/d2	Montagebohrung									
140	315	45	90	40	80	36	31,5	25,5	150	22/33	M16 x 37									
	355																			
	400																			
	315																			
	400																			
190	315	45	90	40	80	36	31,5	25,5	150	22/33	M16 x 37									
	400																			
	315																			
	400																			
	315																			
240	500	56	160	40	160	36	31,5	30,5	250	26/40	M16 x 37									
	630																			
	500																			
	630																			
	500																			
290	500	56	160	40	160	36	31,5	30,5	250	26/40	M16 x 37									
	630																			
	500																			
	500										71	160	40	160	36	31,5	30,5	250	26/40	M20 x 41

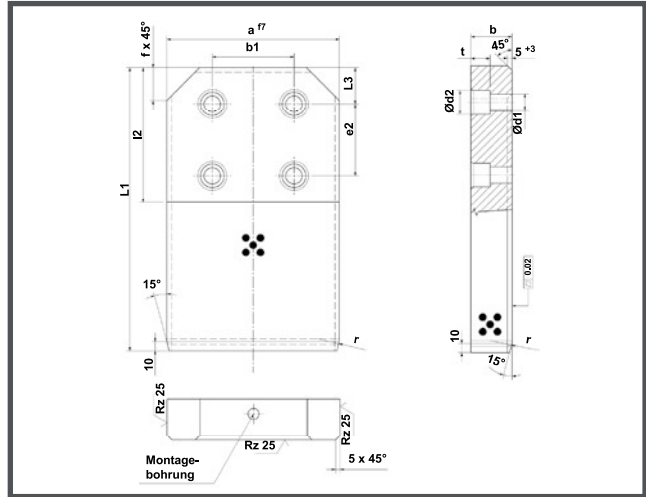
Maße ohne Toleranzangabe | DIN ISO 2768 mittel