

612. Schneidstempel ISO 8020, Form E

**i** Produkteigenschaften

**Material:** HSS (1.3343)

**Härte:** Schaft:  $64 \pm 2$  HRC  
Kopf:  $50 \pm 5$  HRC

Andere Materialien und Abmessungen auf Anfrage.

Zeichnung zu 612.

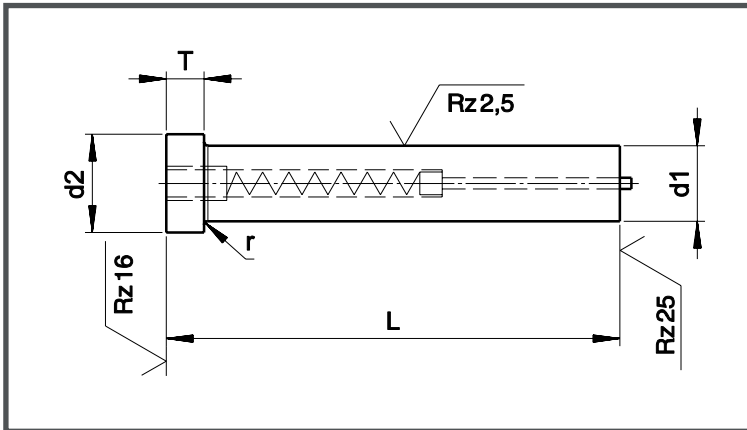

Tabelle zu 612.

| D1 m5          | D3 -0,25 | T +0,25 | r +0,1 | L +0,5 |    |     |     |     |
|----------------|----------|---------|--------|--------|----|-----|-----|-----|
|                |          |         |        | 71     | 80 | 100 | 120 | 130 |
| Standardlängen |          |         |        |        |    |     |     |     |
| 4,0            | 6        | 3       | 0,25   | ●      | ●  | ●   | ●   | ●   |
| 5,0            | 8        | 5       |        | ●      | ●  | ●   | ●   | ●   |
| 6,0            | 9        | 5       |        | ●      | ●  | ●   | ●   | ●   |
| 8,0            | 11       | 5       |        | ●      | ●  | ●   | ●   | ●   |
| 10,0           | 13       | 5       |        | ●      | ●  | ●   | ●   | ●   |
| 13,0           | 16       | 5       | 0,4    | ●      | ●  | ●   | ●   | ●   |
| 16,0           | 19       | 5       |        |        | ●  | ●   | ●   | ●   |
| 20,0           | 23       | 5       |        |        | ●  | ●   | ●   | ●   |
| 25,0           | 28       | 5       |        |        | ●  | ●   | ●   | ●   |
| 32,0           | 35       | 5       |        |        | ●  | ●   | ●   | ●   |

Bestellbeispiel:

612.1000.080  
Schneidstempel ISO 8020-E, HSS  
D1 = 10,0 mm  
L = 80,0 mm