

D8977. Schneidbuchsen mit Bund
nach ISO 8977, HSS, mit Startbohrung und zylindrischer Freimachung

i Produkteigenschaften

Material: HSS (1.3343)
Härte: 64 ± 2 HRC
Form B: mit Bund gehärtet, angelassen und geschliffen
 Ausführungen mit Zentrieransatz
 Andere Abmessungen und Materialsorten auf Anfrage.

Bestellbeispiel:

D8977.2000.025
 Schneidbuche nach ISO 8977, Form B, HSS, Form rund
 D2 = 20,0 mm
 L1 = 25,0 mm
 Startbohrung: D1 = 1,5 mm, L2 = 8,0 mm

Zeichnung zu D8977.

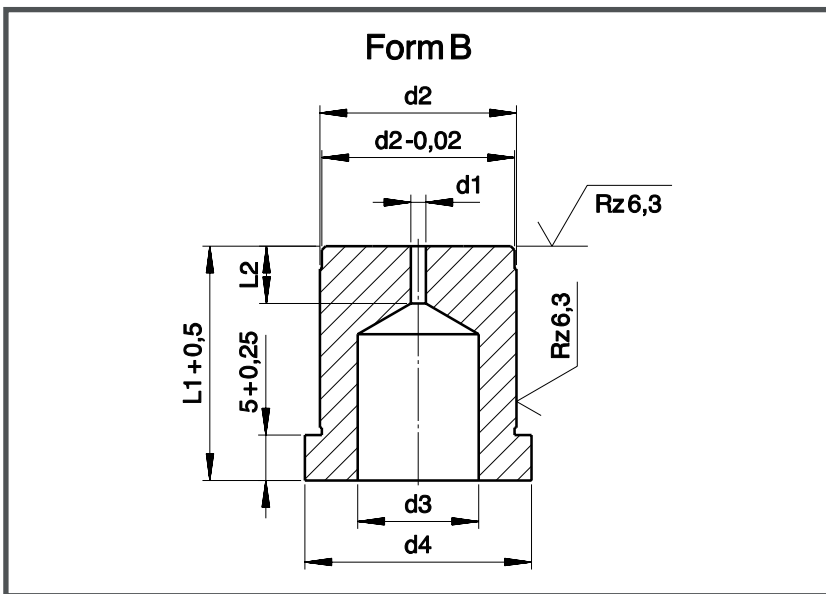

Tabelle zu D8977.

D1 H8	D2 m5	D3	D4 -0,25	L1 +0,5						L2
				16	20	25	30	32	35	
0,8	5	2,8	8	●	●	●				2
0,8	6	3,5	9	●	●	●				3
1,0	8	4,0	11	●	●	●	●	●	●	4
1,0	10	5,8	13	●	●	●	●	●	●	4 + 8
1,2	13	8,0	16	●	●	●	●	●	●	5 + 8
1,2	16	9,5	19	●	●	●	●	●	●	
1,5	20	12,0	23	●	●	●	●	●	●	8 + 12
1,5	25	17,3	28	●	●	●	●	●	●	
1,5	32	20,7	35	●	●	●	●	●	●	
1,5	40	27,7	43		●	●	●	●	●	
1,5	50	37,0	53		●	●	●	●	●	
2,0	56	41,0	59			●	●	●	●	
2,0	63	46,0	66			●	●	●	●	