

F8977. Schneidbuchsen mit Bund
nach ISO 8977, HSS, mit durchgehendem Startloch

i Produkteigenschaften

Material: HSS (1.3343)

Härte: 64 ± 2 HRC

Ausführung:
gehärtet, angelassen und geschliffen

Zeichnung zu F8977.

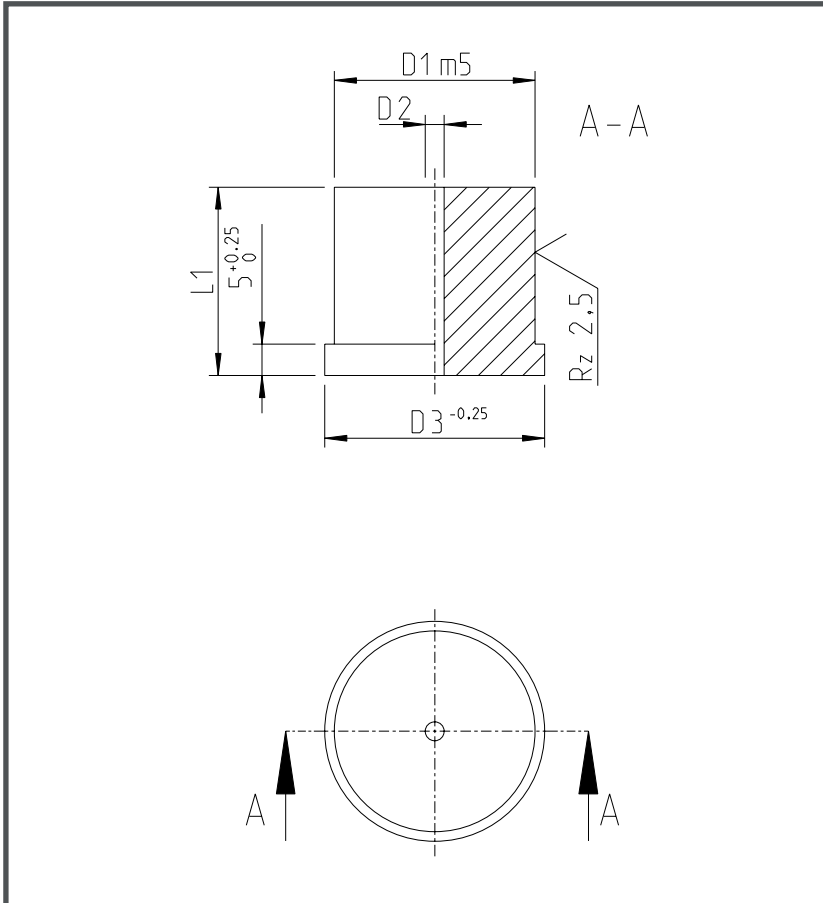

Tabelle zu F8977.

D1	D1-Toleranz	D3	D2 ±0,1	L1						L2
10,0	m5	13,0	1,2	22,0	25,0	28,0	30,0	32,0	35,0	5,0
13,0		16,0	1,4							
16,0		19,0	2,0							
20,0		23,0	2,4							
22,0		25,0								
25,0		28,0								
32,0		35,0								
38,0		41,0								
40,0		43,0								
45,0		48,0								

Bestellbeispiel:

F8977.1000.022
Schneidbuchsen mit Bund,
mit durchgehendem Startloch, HSS
D1 = 10,0 mm
L1 = 22,0 mm